

REVISIONS		DATE	APPROVED
REV.	DESCRIPTION		
1	INITIAL RELEASE	5/25/2005	

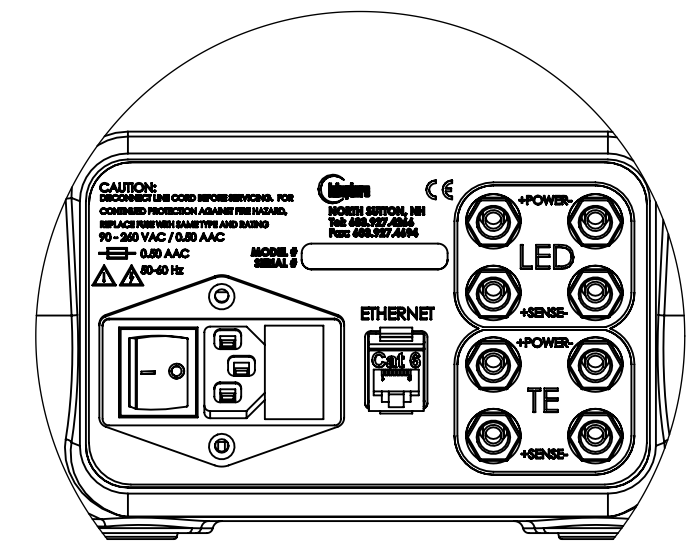
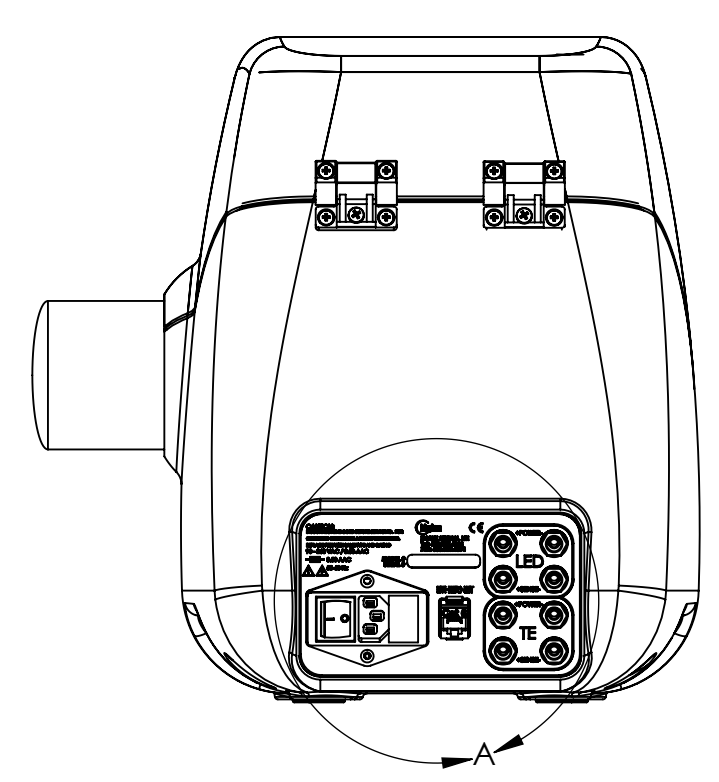
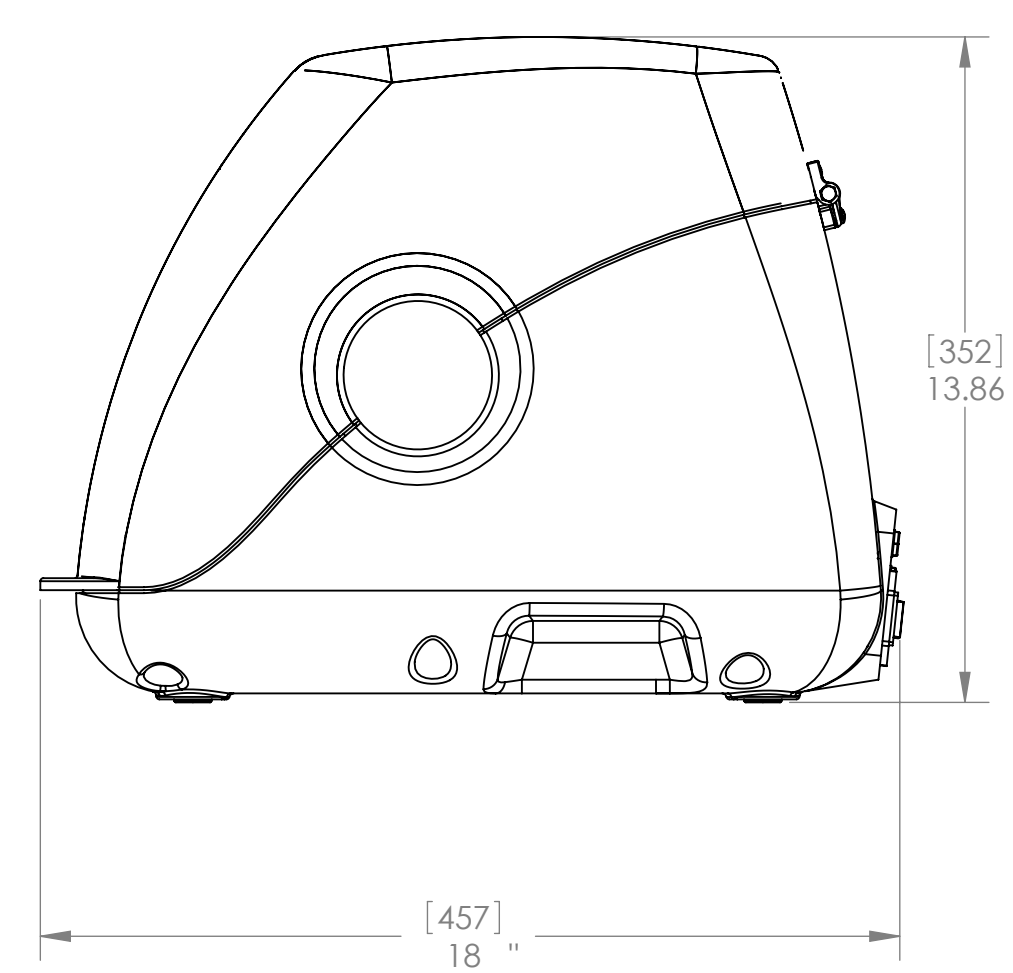
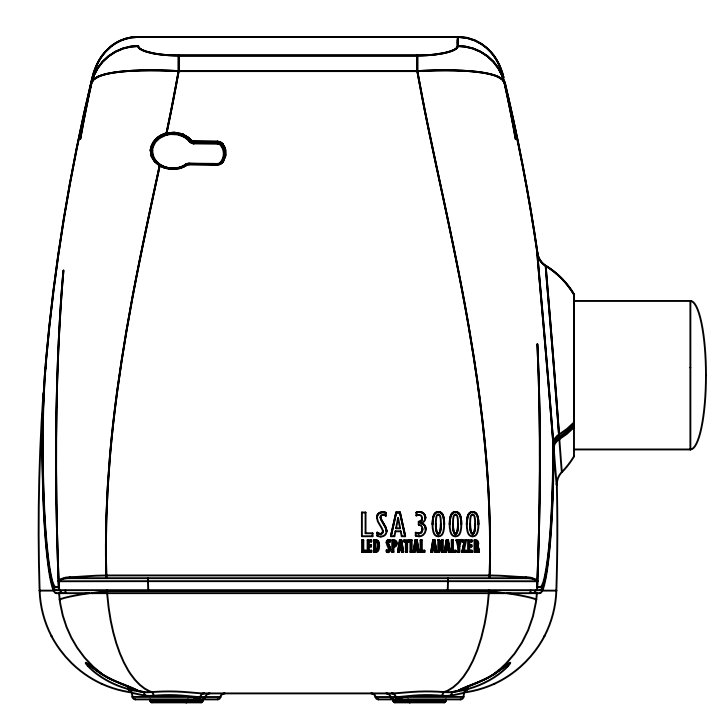
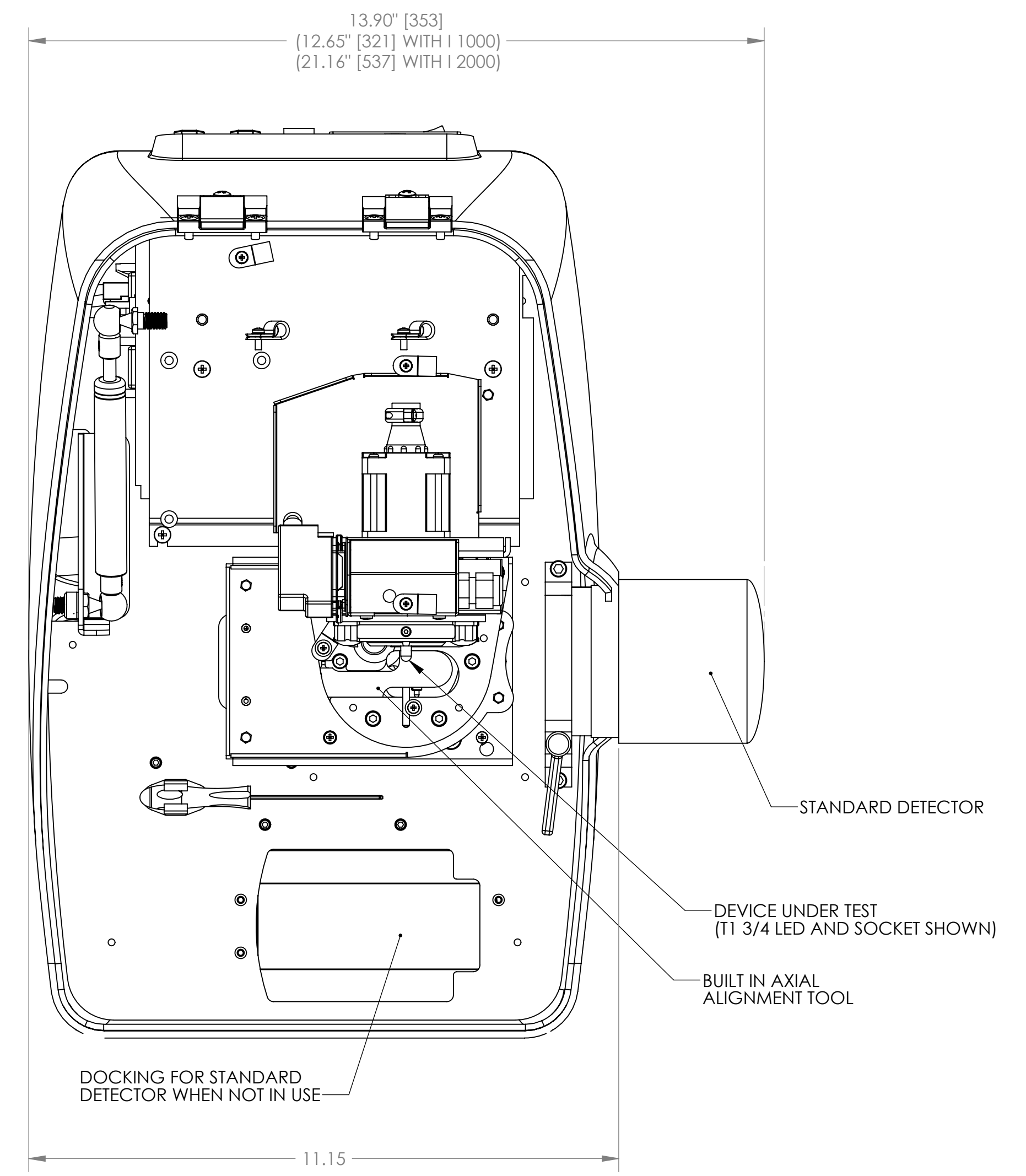
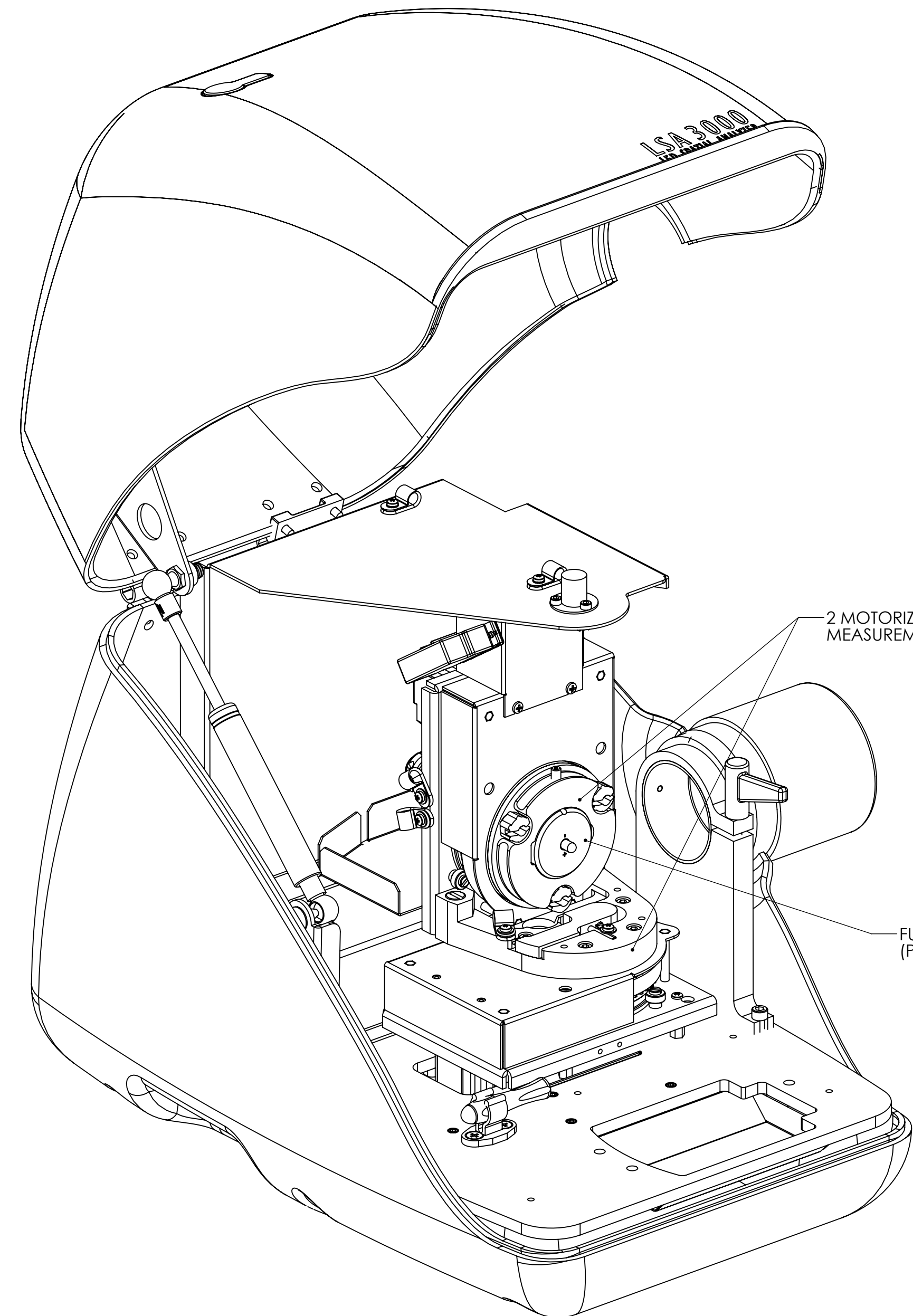

REAR VIEW SHOWING CONNECTIONS
DETAIL A

PRELIMINARY

UNLESS OTHERWISE SPECIFIED, DIMENSIONS ARE IN INCHES. TOLERANCES ARE: FRACTIONS DECIMALS ANGLES HOLE POSITION ±0.01 ±30 HOLE DIA ±0.005 ±0.005 IS PROHIBITED

THE INFORMATION CONTAINED IN THIS DRAWING IS THE SOLE PROPERTY OF Labsphere, Inc. ANY REPRODUCTION IN PART OR IN WHOLE WITHOUT THE WRITTEN PERMISSION OF Labsphere, Inc. IS PROHIBITED.

CAD GENERATED DRAWING. DO NOT MANUALLY UPDATE.

LSA 3000 SUBASSY

APPROVALS	DATE	SIZE	SCALE	SHEET
RESP ENG	6/28/2004	D	1:2	1 OF 1

LABSPHERE
PO BOX 70
231 SHAKER STREET
NORTH SUTTON, NH
03260

AS-02707-000